

Comparative Analysis of STATCOM with & without DVR for Power Quality Improvement

Bhupendra Singh Niranjana, Sachin Vimal, Diya Gupta, Abhishek Kumar, Chanchal Yadav

Department of EE, MG Institute of Management & Technology, Lucknow, India

Abstract:- Nowadays, power quality is the main problem in electrical and electronics engineering because power electronics devices and semiconductor devices are more sensitive to voltage variation. In the current scenario, we move towards non-conventional energy resources to continue power supply like wind, solar. In this paper, we represent an improvement of supply voltage waveform using statcom with and without DVR.

1. Introduction

Nowadays, electric power's reliability and quality are some of the most discussed topics in the power industry. There are numerous types of Quality issues, and each of them might have varying and diverse causes. The types of Power Quality problems a customer may encounter classified depending on how the voltage waveform is being distorted. There are transients, short duration variations (sags, swells and interruption), long-duration variations (sustained interruptions, under voltages, overvoltages), voltage imbalance, waveform distortion (dc offset, harmonics, inter harmonics, notching, and noise), voltage fluctuations and power frequency variations. Three Power Quality problems have been identified as major concerns to the customers: voltage sags, harmonics, and transients. This paper is focusing on these major issues [1].

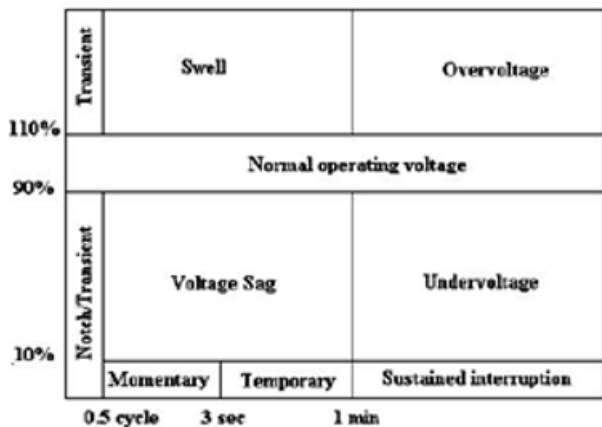

Fig.1: Demarcation of the various Power Quality issues defined

Power Quality has become one of the most prolific buzzwords in the power industry since the late 1980s. Both electric utilities and end-users of electrical energy are becoming increasingly concerned about electric power quality. Electrical Power Quality is the degree of any deviation from the voltage magnitude and

frequency's nominal values. Power Quality problems concerning frequency deviation and voltage magnitude deviations because of harmonics and voltage fluctuations. Other voltage problems are the voltage sags, short interruptions and transient overvoltage. In this paper, the main focus is made on the following problems and their mitigation. The distinction of the various Power Quality issues defined by IEEE Standard, 1159-1995 is described in figure 1.

2. Power quality issues

In an electrical power system, there are various kinds of PQ disturbances. They are classified, and their descriptions are important to classify measurement results and to describe[2-3]

A. Sag

The normal voltage level decrease between 10 and 90% of the nominal RMS voltage at the power frequency in durations of 0,5 cycle to 1 minute. Voltage sag can cause loss of production in automated process since a voltage sag trip a motor or cause its controller to malfunction, namely microprocessor-based control system, programmable logic controller, adjustable speed drives, that may lead to a process stoppage, tripping of contactors and loss of efficiency of the electric machine. The impact of long duration variation is greater than those of short duration variation.

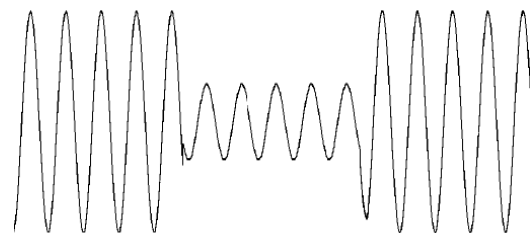

Figure 2: Voltage Sag

Causes: Faults on the transmission or distribution network (most of the times on parallel feeders). Faults in consumer's installation. Connection of heavy loads and start-up of large motors.

Consequences: Malfunction of information technology equipment, namely microprocessor-based control systems (PCs, PLCs, ASDs), may lead to a process stoppage. Tripping of contactors and electromechanical

relays. Disconnection and loss of efficiency in electric rotating machines.

B. Swell

Voltage swell is the rise in voltage of greater than 1.1 p. u. and exists for less than one minute, shown in figure 3. Swells are usually associated with system fault conditions, but they are much less common than voltage sags. A swell can occur due to a single line-to-ground fault on the system, resulting in a temporary voltage rise on the other unwanted phases. Swells can also be caused by switching off a large load or switching on a large capacitor bank. Voltage swells can put stress on the computer and many home appliances. It also causes tripping of the protective circuit of an adjustable speed drive.

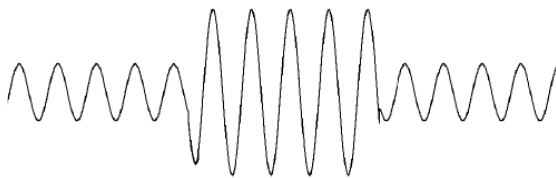

Fig.3: Voltage Swell

Causes: Start/stop heavy loads, badly dimensioned power sources, badly regulated transformers (mainly during off-peak hours).

Consequences: Data loss, a flickering of lighting and screens, stoppage, or sensitive equipment damage if the voltage values are too high.

C. Transient

Voltage Transients are defined as short duration surges of electrical energy and result from the sudden release of energy previously-stored or induced by other means, such as heavy inductive loads or lightning. In electrical or electronic circuits, this energy can be released predictably via controlled switching actions or randomly induced into a circuit from external sources.

Table 1: Example of Transient source and magnitude

	Voltage (KV)	CURRENT (KA)	Rise time (µs)	Duration (ms)
Lighting	25	20	10	1
Switching	600	500	50	500
EMP	1	10	20	1
ESD	15	30	< 1	100

Repeatable transients are frequently caused by motors, generators, or the switching of reactive circuit components. On the other hand, random transients are often caused by Lightning and Electrostatic Discharge (ESD). Lightning and ESD generally occur unpredictably

and may require elaborate monitoring to be accurately measured, especially if induced at the circuit board level. Numerous electronics standards groups have analysed transient voltage occurrences using accepted monitoring or testing methods. The key characteristics of several transients are shown in the table below. Transient voltage spikes generally exhibit a "double exponential" wave, as shown below for lightning and ESD.

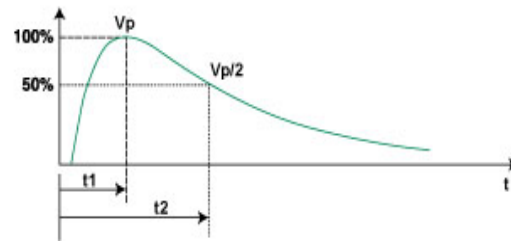

Figure 4: Lightning and transient waveform

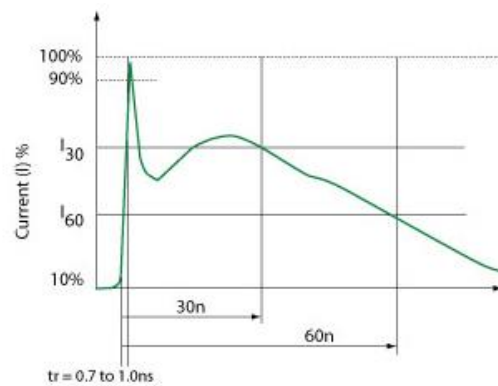

Figure 5: ESD test Waveform

D. Voltage Flicker

Voltage flicker is one of the power quality problems. Due to sudden switching on and off of loads on a weak distribution system, voltage flicker occurs. Voltage variations occur due to the small short circuit capacity in the distribution system. It results in rapid voltage variation due to fast changes in load, as shown in figure 6. While starting large motors, there is a decrease in voltage due to an inrush current requirement. This decrease in voltage cause voltage flicker on other loads which are connected to the same distribution system. This voltage flicker is very dangerous to sensitive loads; thus, voltage flicker is one of the major power quality problems. The voltage flicker magnitude depends upon the type of electrical load that is producing the disturbance. Voltage flicker can also occur due to the sag in the power system. This voltage sag can generate an inrush current, and this current passes into the sensitive loads in the distribution system.

Causes: Arc furnaces, frequent start/stop of electric motors (for instance, elevators), oscillating loads.

Consequences: Most consequences are common to under voltages. The most perceptible consequence is the flickering of lighting and screens, giving the impression of visual perception instability.

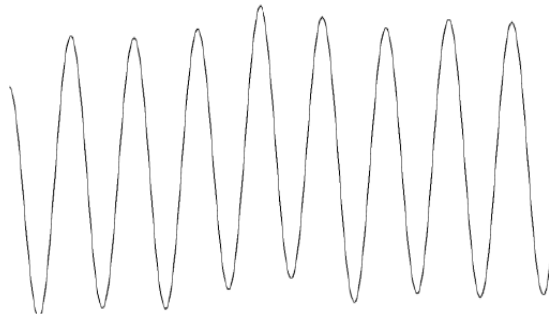

Figure 6: Voltage Flicker

E. Power Frequency Variation

Power frequency variations are a deviation from the nominal supply frequency. The supply frequency is a function of the generators' rotational speed to produce electrical energy. At any instant, the frequency depends on the balance between the load and the capacity of the available generation.

A frequency variation occurs if a generator becomes un-synchronous with the power system, causing an inconsistency manifested in a variation. The specified frequency variation should be within limits $\pm 2.5\%$ Hz at all times for the grid network.

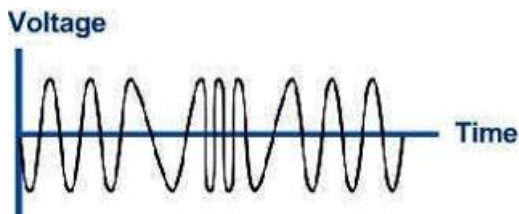

Figure 7: power frequency variation

F. Dc In Ac Networks

One of the known effects caused by the presence of DC components in the AC networks is the DC saturation of transformers connected to the AC lines. It is shown that the standard instrument transformers used in the AC power circuits are not significantly affected by the DC components caused by the operation of the DC line.

G. Harmonics ,Interharmonics

IEEE describes harmonics as sinusoidal voltages or currents having frequencies that are integer multiples of the fundamental frequency at which the power system is designed to operate. For a 60-Hz system, the harmonic frequencies are 120 Hz (2nd harmonic), 180 Hz (3rd

harmonic). Harmonics combine with the fundamental voltage or current, producing a non-sinusoidal shape; thus, waveform distortion is a power quality problem. The non-sinusoidal shape corresponds to the sum of different sine waves with different magnitudes and phase angles, having frequencies multiplying the system frequency.

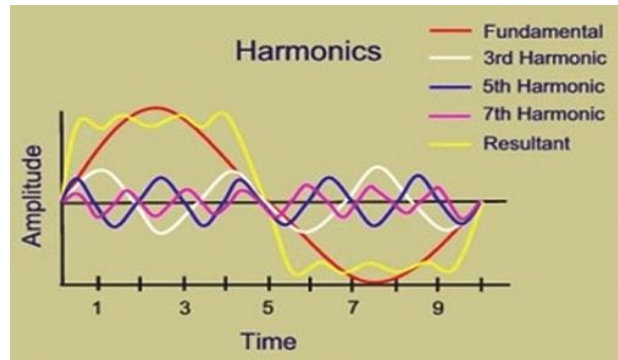

The complete harmonic spectrum can characterise harmonic distortion levels with magnitudes and phase angles of each harmonic component. It is common to use the Total Harmonic Distortion (THD) to measure the effective harmonic distortion value. It has become an increasing concern for many end-users and the overall power system because of the growing application of power electronics equipment. Protection from high harmonics levels includes isolation or modification of the source, phase multiplication, pulse width modulator (PWM), and passive or active harmonic filters.

Cause: Harmonics exists due to the nonlinear characteristics of loads and devices on the electrical power system. These devices can be modelled as current sources that inject harmonic currents into the electrical system. Consequently, voltage distortion is created as these currents produce nonlinear voltage drops across the system impedance. Before the proliferation of power electronic equipment, harmonics are commonly caused by electric machines working above the magnetisation curve's knee (magnetic saturation), arc furnaces, welding machines, rectifiers, and DC brush motors. Today, all nonlinear loads, such as power electronics equipment including Switched Mode Power Supplies (SMPS), Adjustable Speed Drives (ASD), high-efficiency lighting and data processing equipment.

Consequences: Harmonics primarily result in significant overheating of equipment, cables and wires. Other consequences of having a high harmonic level in the system include the following:

- Neutral overload in 3-phase systems
- Electromagnetic interference with communication systems
- Loss of efficiency in electric machines

- Increased probability in the occurrence of resonance
- Nuisance tripping of thermal protection.
- Errors in measures when using average reading meters

4. Mitigation Technique of Power Quality By Using Statcom

Manufacturers have developed a range of equipment to help consult engineers and facility personnel address specific power-quality issues. In some cases, the options are pretty cut and dried, while situations may require a bit more thought.

- *Transients:-* Transient voltage surge suppressors are the best option for protecting against transients in a power system.
- *Voltage sags and interruptions:-* The best choice here depends on the extent of any interruption. Uninterruptible power supplies and other energy-storage options could do well with shorter-term sags or interruptions. Still, backup generators or self-generation equipment is needed when longer outages are encountered. Other solutions could include static transfer switches and dynamic voltage restorers with energy storage.
- *Harmonics:-* Active filters are the recommended solution for harmonic mitigation, thanks to their flexibility and high correction performance. Alternative approaches could involve passive filters, multi-pulse arrangement transformers or harmonic correction at the equipment level (for example, integrating harmonic filtering into variable speed drives). The AccuSine power-correction system from Schneider Electric offers a complete harmonic-filtering solution.
- *Power factor:-* Reducing the power factor requires producing reactive energy as close as possible to connected loads. Installing capacitors on the network, such as Schneider Electric's VarSet LV capacitor banks, is the easiest and most common way to achieve this goal.

A. STATCOM with Active Energy Storage

STATCOM is a shunt compensator based on usually multi-level VSC design, utilising IGBT (Insulated Gate Bipolar Transistor) as reliable high speed switching elements and a control concept based on pulse-width modulation. The VSC operates as a fully controllable voltage source matching the system voltage in phase, frequency, and amplitude, controlled continuously and rapidly to control reactive power [4]. The typical STATCOM connection shown in figure 9. STATCOM allows voltage stabilisation, improvement of power factor and dynamic control at the

point of connection to industrial load using reactive power compensation. It is not enough when a variable load is connected to the grid and produces voltage fluctuations. Using additional active power compensation is required because the voltage drop is caused by reactive and active power consumption (1).

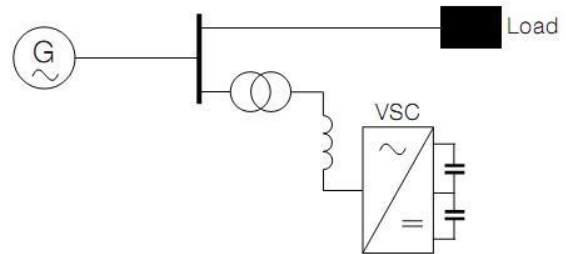

Figure 9: STATCOM connection

$$\Delta \hat{U}_{ph} = \hat{Z} \hat{I} = (R + jX) \frac{P \mp jQ}{\sqrt{3}U} = \frac{RP \pm XQ}{\sqrt{3}U} + j \frac{XP \mp RQ}{\sqrt{3}U} \quad (1)$$

Equation (1) has an upper sign "+" in the real part for inductive and bottom "-" for capacitive load character. We can see from this formula that voltage drop cannot be eliminated just by compensating reactive power. However, using active power injection can eliminate small, fast voltage disturbances during a variable load operation. Such disturbances are the main cause of flicker in transmission and distribution grids. STATCOM with active power compensation could be realised by adding an element that can inject and consume active power, i.e., storing active energy. The parallel connection of a battery can reach it to the DC capacitor. STATCOM uses VSC technology which enables 4-quadrant operation in case of active power exchange possibility. It makes it possible to convert AC to DC and back for active current. Usage of active power compensation has a big potential for many applications, such as:

- voltage and power compensation in distribution and transmission systems
- power compensation during short-circuits and network reconfigurations
- stability increasing during grid reconfigurations or generator failures
- compensation of voltage dip during short time failure

One of the problems which have to be solved is VSC control for active power flow. Classical STATCOM (Q-Compensation) Control Is Realised Using Difference between the converter output voltage and the grid voltage magnitudes. Phase angle differences can realise active power compensation control. In this case, phasor measurement units (PMU) can be used.

Another problem is the battery's dynamic characteristic, fast reaction to power changes in the grid, and compensation. However, modern technologies and trends in battery development are promising. A suitable energy storage system for STATCOM depends on its application. In the case of the function to compensate active power fluctuations in terms of minutes, e.g., at renewable sources, a huge battery is supposed to be the right solution. Some manufacturers also present a device capable of accumulating the active power in the range of tens of MW for tens of minutes. Other technologies seem to be promising, like capacitors, ultra-capacitors, flywheels, or some new battery types in power-quality tasks.

B. Compensation model

STATCOM can be represented as a shunt current source. By controlling the magnitude and the phase angle of the VSC output voltage, both active and reactive power can be controlled and exchanged between STATCOM, the load and the grid, i.e., all 4 VSC quadrants are used. R and L are common resistance and inductance of the grid and the distribution transformer. C is an internal DC capacitance. R_s usually represent internal converter losses, but it is used as the controllable storage resistance in this model. It allows the current i_{rd} controlling.

C. Statcom Control:

A typical STATCOM control system is shown in Fig. Current, and voltage input signals are used to Evaluate the compensating current [5]. The flicker controller evaluates reference active and reactive compensating currents. The flicker meter Calculates phase flicker and compares it with the reference flicker level in the voltage control block. The reactive reference current is evaluated for power factor requirements. Active current is obtained concerning energy storage rate.

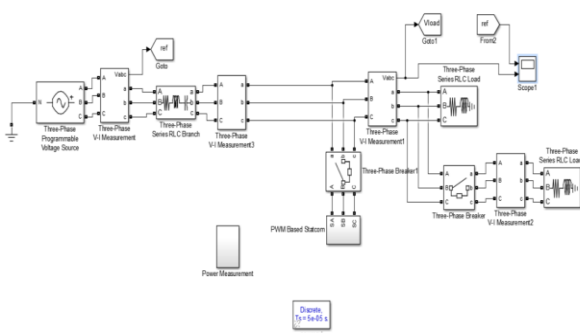

Figure10:Mitigation of PQ by using STATCOM

D. Voltage Control at Electric Arc Furnace:

Steelworks currently operated globally are usually equipped with an electric arc furnace as a melting unit and a ladle furnace (LF) refining steel with the subsequent

continuous process of further steel processing. EAF is used to transform scrap to melt in most cases, and therefore large power of tens of MVA is needed for its operation. Ladle furnace works with the melt, and therefore not so much power as for the EAF is needed for its operation. Supply voltage has a sinusoidal shape, but the arc current has a chaotic and very much disturbed time behaviour. Differences between the supply voltage and the arc voltage are large. These differences affect the power circuit. The circuit's impedance comprises the furnace transformer reactance and a short way upstream reactance or a choke (reactor).

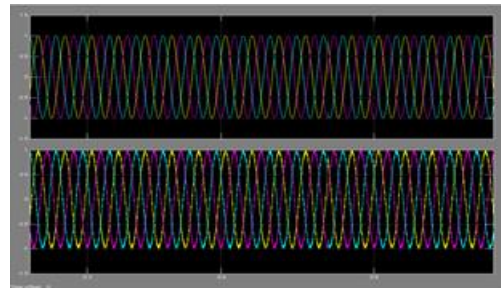

Figure 11: resultant waveform after using STATCOM

The load current is non-sinusoidal and lags behind the voltage due to the inductive impedance characteristics. Fluctuations in voltage that the furnace creates are irregular. EAF impedance variable character loads the electrical network by peak currents which range from zero values during arc interruption to three-phase short-circuit current at the electrodes inside the melt.

5. Mitigation Of Power Quality By Using Statcom With Dvr

PQ problems mitigation may occur at different levels: transmission, distribution, and end-use equipment. Several measures can be taken at these levels.

A. Grid Adequacy

Many PQ problems have their origin in the transmission or distribution grid. Thus, with adequate planning and maintenance, a proper transmission and distribution grid is essential to minimise PQ problems [6].

B. Distributed Resources

Energy Storage Systems Interest in the use of distributed energy resources (DER) has increased substantially over the last few years because of their potential to increase reliability. These resources include distributed generation and energy storage systems. Energy storage systems, also known as restoring technologies, are used to provide the electric loads with ride-through capability in a poor PQ environment. The first energy storage technology used in PQ, yet the most used today, is an electrochemical battery. Although new technologies, such as flywheels, supercapacitors and superconducting magnetic energy storage (SMES), present many

advantages, electrochemical batteries still rule due to their low price and mature technology.

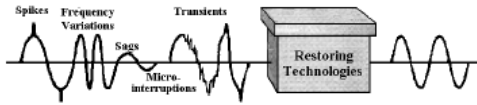

Figure 12: the principle of power restoration

C. Distributed Resources – Distributed Generation

Distributed Generation (DG) units can provide clean power to critical loads, isolating them from disturbances with origin in the grid. DG units can also be used as backup generators to assure energy supply to critical loads during sustained outages. Additionally, DG units can be used for load management purposed to decrease the peak demand.

D. Enhanced Interface Devices

Besides energy storage systems and DG, some other devices may be used to solve PQ problems. Using proper interface devices, one can isolate the loads from disturbances deriving from the grid[7].

A. **Dynamic Voltage Restorer:** A dynamic voltage restorer (DVR) acts like a voltage source connected in series with the load. The output voltage of the DVR is kept approximately constant voltage at the load terminals by using a step-up transformer and stored energy to inject active and reactive power in the output supply through a voltage converter.

B. **Transient Voltage Surge suppressors (TVSS):** Transient voltage surge suppressors are used as an interface between the power source and sensitive loads so that the TVSS clamps the transient voltage before it reaches the load.

C. **Constant Voltage Transformers:** Constant voltage transformers (CVT) were the first PQ solutions to mitigate voltage sags and transients' effects. To maintain the voltage constant, they use two principles that are normally avoided: resonance and core saturation.

D. **Noise Filters:** Noise filters are used to avoid unwanted frequency current or voltage signals (noise) from reaching sensitive equipment. It can be accomplished using a combination of capacitors and inductances that creates a low impedance path to the fundamental frequency and high impedance to higher frequencies, that is, a low-pass filter.

E. **Isolation Transformers:** Isolation transformers isolate sensitive loads from transients and noise deriving from the mains. In some cases (Delta-Wye connection), isolation transformers keep harmonic currents generated by loads from getting upstream the transformer.

F. **Static VAR Compensators:** Static VAR compensators (SVR) use a combination of capacitors and reactors to regulate the voltage quickly. Solid-state switches control the capacitors and reactors' insertion at the

right magnitude to prevent the voltage from fluctuating.

G. **Harmonic Filters:** Harmonic filters are used to reduce undesirable harmonics. They can be divided into two groups: passive filters and active filters. Passive filters consist of a low impedance path to the harmonics' frequencies to be attenuated using passive components (inductors, capacitors and resistors). Active filters analyse the load's current and create a current that cancels the loads' harmonic current.

E. Develop Codes and Standards

Some measures have been taken to regulate the minimum PQ level that utilities have to provide to consumers and the immunity level that equipment should have to operate properly when the power supply is within the standards [8, 10]. One major step in this direction was taken with the CBEMA curve, created by the Computer and Business Equipment Manufacturer's Association.

F. Make End-use Devices Less Sensitive

Designing the equipment to be less sensitive to disturbances is usually the most cost-effective measure to prevent PQ problems. Some end-use equipment manufacturers now recognise this problem, but the competitive market means that manufacturers should reduce costs and only respond to customers' requirements.

G. PROPOSED HYBRID MODEL

The proposed system explores the effect of using STATCOM and DVR to improve power quality.

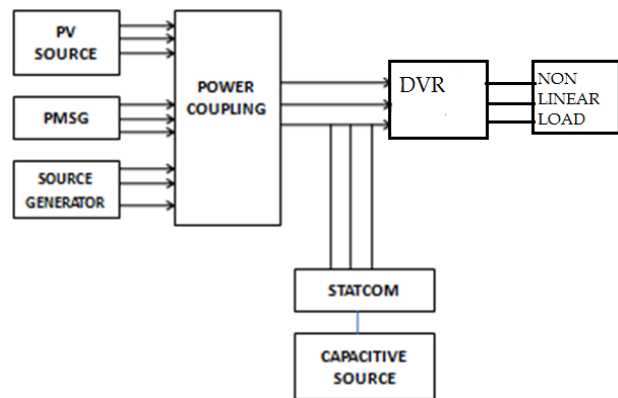

Figure.13: Proposed Hybrid Model.

Proposed Hybrid Model:- The Above block shows the proposed scheme in which the DVR and STATCOM. The figure above shows the grid or the infinite bus connected to the grid. It shows the WTIG, a nonlinear load for harmonics generation. The DVR and STATCOM are used for Active filtering. They cancel the effect of voltage sags and swells by injecting a voltage into the

system and remove the harmonics by injecting a current into the system [9].

H. STATCOM Operation

The wind turbine is initialised first, then comes into a running state, and when the Nonlinear load connected to the system, the voltage and current at the grid distorted and need to be filtered. Here, the STATCOM (Active filter) activated and injected the exact current into the system needed to cancel the harmonics' effect. This reference injected current generated by the hysteresis control technique.

I. DVR operation

When a wind turbine is initially connected to the grid, it needs reactive power for the induction generator to produce electric power. It causes the voltage to drop at the grid. At this instant, the DVR should start its operation and compensate for the voltage drop at the critical load.

J. Results

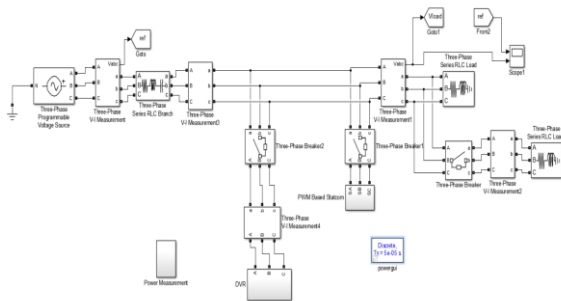

Fig.14: Mitigation using STATCOM and DVR

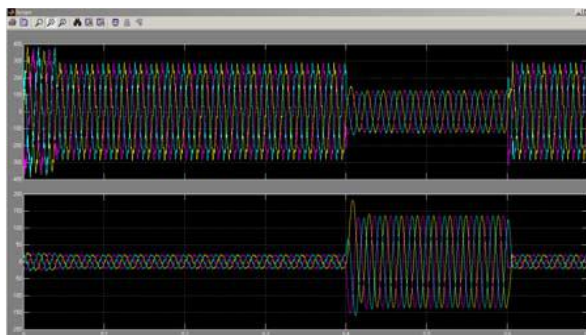

Figure 15: System Load voltage and current

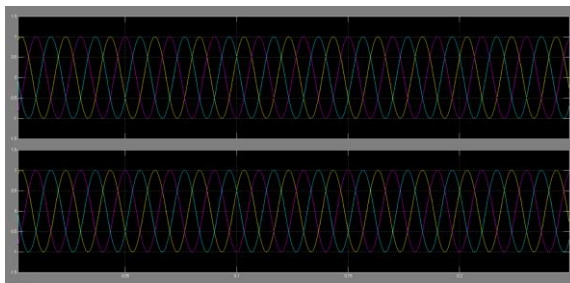

Figure 16: Active, reactive power of the system STATCOM with DVR

The proposed simulation model We have connected a STATCOM for the removal of harmonics and DVR for injecting compensation voltage fault is injected in the system at time $t = 0.4$ to $t = 0.6$. The simulation results are given below [9].

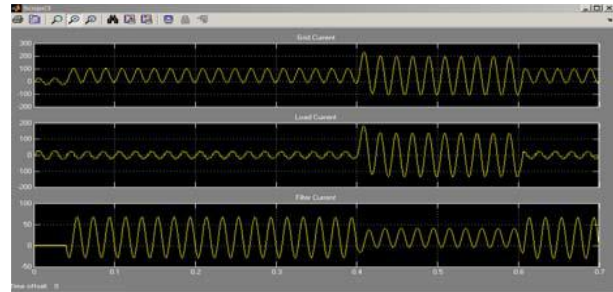

Figure 17: STATCOM removing harmonics DVR

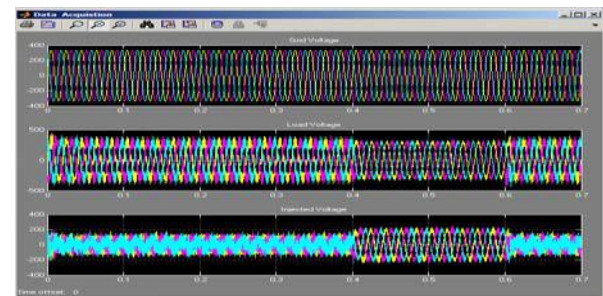

Figure 18: DVR Injecting voltage

6. Conclusion

This paper presents various power quality issues and their consequences on the consumer, electric utility, and various mitigation techniques to improve power quality. The power system power quality of the grid is affected due to voltage sag, voltage swell, voltage flicker, harmonics and power factor. This problem can be solved using statcom and dvr connect in the transmission line series to reduce voltage swelling. The dvr also used to fulfil the need for RMS voltage needed by consumers. The statcom supply and consume reactive and active power as for the requirement.

Reference

- [1] EurObserv'ER annual report "the State of Renewable Energies in Europe", Management of Environmental Quality: An International Journal, 2013.
- [2] M. Bollen, "Understanding Power Quality Problems- Voltage Sags and Interruptions", IEEE Press Series on Power Engineering - John Wiley and Sons, Piscataway, USA (2000).
- [3] M. McGranaghan, "Costs of Interruptions", in proceedings of the Power Quality 2002 Conference, Rosemont, Illinois, pp 1-8, October 2002.
- [4] Yanushkevich A, Tlustý J: Active Power Compensation in Industrial Applications Using Statcom with Supercapacitors, 2012 IEEE 12th

International Conference on Probabilistic Methods Applied to Power Systems, PMAPS 2012, p. 1-4

- [5] Zhiping Yang; Crow, M.L.; Chen Shen; Lingli Zhang: The steady-state characteristics of a StatCom with energy storage. Power Engineering Society Summer Meeting, 2000. IEEE. Publication Year: 2000 , Page(s): 669- 674 vol. 2
- [6] Johnson Abraham Mundackal, Sreekala P. "Grid Power Quality Improvement and Battery Energy Storage in Wind Energy Systems" International Conference on Microelectronics, Communication and Renewable Energy (2013).
- [7] Dae-Wook Kang, Woo-Chol Lee, Dong-Seok Hyun "The Distribution STATCOM for Reducing the Effect of Voltage Sag and Swell", Department of Electrical Engineering, Han Yang University, Haeng Dang Dong, Sung Dong GU, SEOUL 133-791.
- [8] Yadav, Amrendra Singh, et al. "Increasing Efficiency of Sensor Nodes by Clustering in Section Based Hybrid Routing Protocol with Artificial Bee Colony." Procedia Computer Science 171 (2020): 887-896.
- [9] IEEE Power Engineering Society, IEEE Standards Board, "IEEE Std 1250-1995, IEEE Guide for Service to Equipment Sensitive to Momentary Voltage Disturbances", Approved March 16, 1995.
- [10] K. R. Padiyar, Facts Controllers in Power Transmission and distribution, new age international distribution, new age international publishers, june 2007 edition, 1st reprint 2009.