

Design and Simulation of Radio Frequency Identification

Ahmed Telba Member IEEE, Khalid Jamil

Abstract—In this paper design and simulation of the Radio Frequency Identification Antenna (RFID) is present ,main part for RFID is the Antenna, design antenna using CST program to get the real results and micro wind and spice to calculated the frequency of the antenna design in the new technology of RFID needing long distance for reading of the information, the main core of transmit and receive the information is the antenna so the design of the antenna is relevant in this paper the design and simulation of the antenna is given using CST STUDIO and Micro wind the magnetic field is present ,S – parameter in both linear and dB , both frequency and time domain signal are simulated S-parameter in both linear and dB are calculating and field energy.

Index Terms— Radio-Frequency Identification (RFID), Antenna, CST, modelling and Simulation, and Tags

Introduction

RFID systems can be used just about anywhere, from clothing tags to missiles to pet tags to food anywhere that a unique identification system is needed. The tag can carry information as simple as a pet owners name and address or the cleaning instruction on a sweater to as complex as instructions on how to assemble a car. Some auto manufacturers use RFID systems to move cars through an assembly line. At each successive stage of production, the RFID tag tells the computers what the next step of automated assembly one of the key differences between RFID and bar code technology is RFID eliminates the need for line-of-sight reading that bar coding depends on. Also, RFID scanning can be done at greater distances than bar code scanning. High frequency RFID systems (850 MHz to 950 MHz and 2.4 GHz to 2.5 GHz) offer transmission ranges of more than 90 feet, although wavelengths in the 2.4 GHz range are absorbed by water (the human body) and therefore has limitations.

Radio-frequency identification, or RFID, is a promising enterprise resource-management technology, but price has slowed adoption after enormous initial buzz. A RFID tag, or transponder, can be attached to materials and goods to automatically transmit data to receivers and then supply-chain management (SCM), ERP and other software. RFID tags can be used to identify pallets of goods in a warehouse or a single item in a retail outlet. A key to RFID adoption is tying indoor tracking to overall SCM systems.

UHF RFID system can be divided to two parts, readers and tags. Generally, an RFID system contains several readers and a large amount of tags in practical application. The colli-

sion problems of both tags and readers are resolved in the arithmetic [1] and MAC protocol [2].

Types of rfid

RFID systems can be classified according to the radio frequency used, the type of modulation used to communicate and the type of tag used in the system.

Radio Frequency: The radio frequency is defined as the frequency of the sine wave generated by the reader to send a request to the tag. Carrier wave frequency is of primary importance in determining data transfer rates. In practical terms the rate of data transfer is influenced primarily by the frequency of the carrier wave used to carry the data between the tag and its reader. Generally speaking the higher the frequency and higher of data transfer that can be achieved. Three frequency ranges are generally pre-defined in RFID systems as low, intermediate (medium) and high as shown in Table.1

TABLE I: RFID FREQUENCY BANDS

Frequency Range	Frequency
Low	100-500 kHz
Intermediate	10-15 MHz
High	2.4-5.8 GHz

A.Low Frequency RFID

The advantage of low frequency RFID is that unlike high frequency RFID systems, they do not require a line of sight between the transponder and the reader antenna. They have an operating range of between 1 and 3 metres. They can use low power levels, therefore making them more acceptable for licensing. The transponders are quite inexpensive, and the low frequency allows for reads through non-metallic.

B.Medium Frequency RFID

Medium frequency RFID (typically 13.56 MHz) is used in Emergency Action Notification (EAS) systems and ISM (Industrial, Scientific and Medical) applications. They have a medium read range, medium data transfer rate, but are less able to permit solids. While the medium frequency RFID systems are more orientation sensitive than the low frequency system, they still do not require a line of sight between the reader and the transponder.

C.High Frequency RFID

High frequency RFID (typically more than 900 MHz) is less acceptable internationally due to licensing issues. These systems are available with operating ranges of 30 metres or more. However, to obtain these ranges, high power levels are required. The ability of these transponders to read through solids is very limited, and it is generally accepted that a line of sight is required between the transponder and the reader unit. The advantage of the high frequency RFID systems is that they have very high data transfer rates afforded to them by the very high carrier frequency.

D.RFID Modulation

Transfer of data between tags and a reader is wireless. Two modulation methods distinguish and categories RFID systems; one based upon close proximity electromagnetic or inductive coupling, as shown in figure 1, and one based upon propagating electromagnetic waves, as shown in figure 1. Coupling is via ‘antenna’ structures that form an integral feature in both tags and readers.

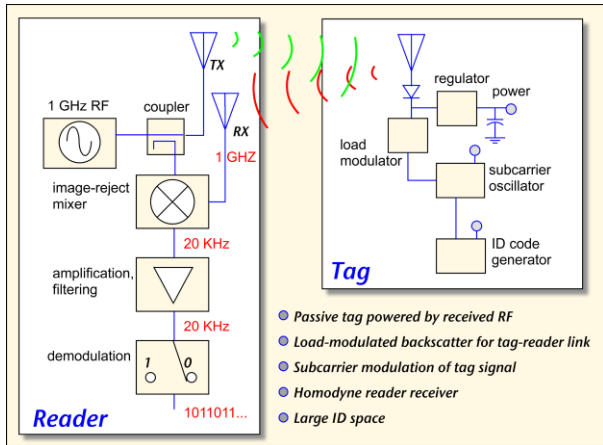

Fig .1 Transferring data between tags and a reader [1-5]

E.RFID Electromagnetic Coupling

Electromagnetic couplings systems are systems in which a magnetic field is used as a means of transferring data or power. Electromagnetic coupling techniques are generally applied to RFID systems operating in the low to medium frequency bands, with relatively short reading distances. Inductive coupling is basically a means of conveying radio frequency energy via an oscillatory high frequency magnetic field. The reader antenna loop and the tag coil windings establish a loosely connected “space transformer” resulting in power transfer across short bidirectional reading distances. Maximum power transfer between the reader antenna coil and the tag coil occurs when the two coupled coils are placed or aligned in the same plane.

F.Design Frequency measurements RFID

Design in high frequency meaning that working in longer read ranges (1m to 9 m) and has benefit of compared to LF/HF tags, Propagating waves are more strictly limited by

regulatory agencies, Read performance affected by signal reflections off and blockage by objects along reader-to-tag propagation path (multipath), Frequency bands shared by other active services, Strongly effected by presence of nearby non-metallic objects, Tags available to work on metal are usually larger and thicker.

Assessing Tag Bandwidth can be done using CST Design Studio as shown in figure .2 the frequency range of S parameter magnitude of designed antenna Figure 3 illustrate Field energy of the antenna.

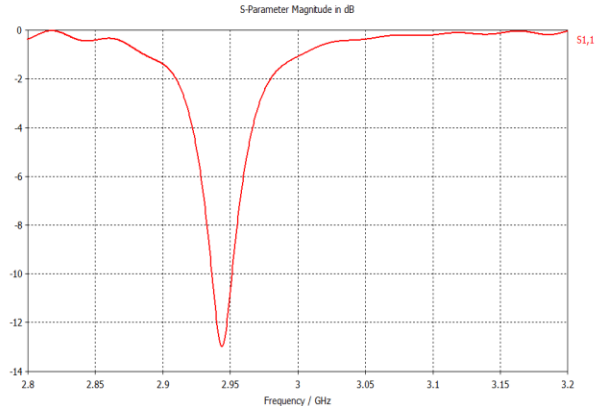

Fig. 2. S parameter magnitude

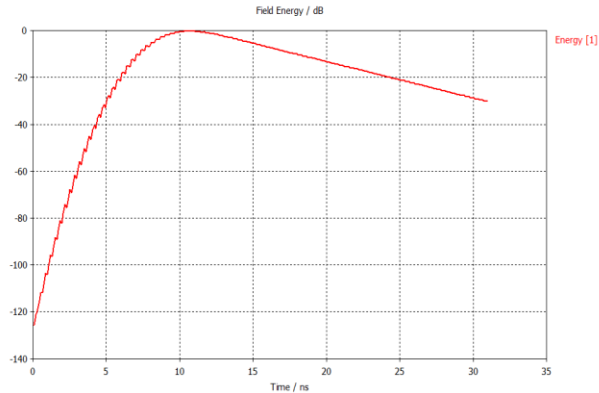

Fig.3 Field energy

The tag received power can be calculated using the Friis formula is given by [13]:

$$P_T = P_i * G_T * \left(\frac{\lambda}{4\pi R^2} \right)^2 * \zeta * P_T * [1 - \Gamma_T^2] \quad (1)$$

where P_i is the reader radiated power, G_T is the gain of tag antenna, λ is the wavelength, R is the propagation distance, ζ is the polarization mismatch factor and Γ_T is the reflection coefficient at the tag antenna. A minimum P_T is typically required to turn on the tag and to allow data transmission through a backscatter wave. The corresponding backscattered received power at the reader can be expressed in the form

$$P_R = P_i * G_R * G_T^2 * \left(\frac{\lambda}{4\pi R^2}\right)^4 * \zeta^2 * p_T * [1 - \Gamma_R^2] \quad (2)$$

where G_R is the gain of reader antenna and Γ_R is the reflection coefficient at the reader antenna.

The investigation of EM wave propagation, attenuation, radiation, and scattering in soil is more complicated. It is well known that soil electrical properties affect the EM wave's propagation properties and thus the radiation and backscattering characteristics of an RFID system. For oil and mining sectors, there are many factors that should be included for a reliable estimate of an RFID system performance. These include electromagnetic waves propagation in soil instead of free space (soil frequency-dependent electrical conductivity (σ) and soil moisture, distance of propagation (R), etc), potential interferences and degradation due to real environmental conditions. We will develop a realistic model in the frequency domain to investigate EM wave's propagation and its attenuation in infinite half-space soil medium. If a plane wave approximation is used for the attenuation, the depth of penetration into the materials is known as skin depth. The skin depth depends on the frequency of the RFID reader antenna used to transmit EM energy into soil and soil properties. It is given by the following formula:

$$\delta = \sqrt{\frac{2}{\omega\mu\sigma}} \quad (3)$$

where σ is the electrical conductivity and μ is the magnetic permeability. The corresponding signal attenuation (α) is given by

$$\alpha = \omega\sqrt{\epsilon\mu} \sqrt{\frac{1}{2} \left(\sqrt{1 + \left[\frac{\sigma}{\omega\epsilon}\right]^2} - 1 \right)} \quad (4)$$

In addition to investigating EM wave propagation in soil, one of our objectives is to implement near field UHF RFID systems using existing and modified reader modules and tag ICs. The approach is to use special near-field reader antennas and tags. New special reader antennas and tags will be designed and implemented to create strong localized magnetic field region.

The important parameters that used RFID Antenna Design are the Gain: Radiation and Directionality of Power this appear in figure. 4 the far field in all coordinate of the designed antenna at frequency F=980MHz.

Radio-Frequency Identification (RFID) is the use of RF radiation to identify physical objects. Automated identification systems include RFID and bar code systems. Unlike bar code systems, RFID systems eliminate "line-of-sight to object" requirements. Figure 5 illustrates a simplified RFID system. The system uses radio reader-tag transmissions to identify a tagged object. Each RFID tag contains an identification number. The RFID reader detects tags through RF radiation backscattered from RFID tags. The tag system rectifies the received RF signal to power the tag circuitry and send a tag identification signal to the reader [1].

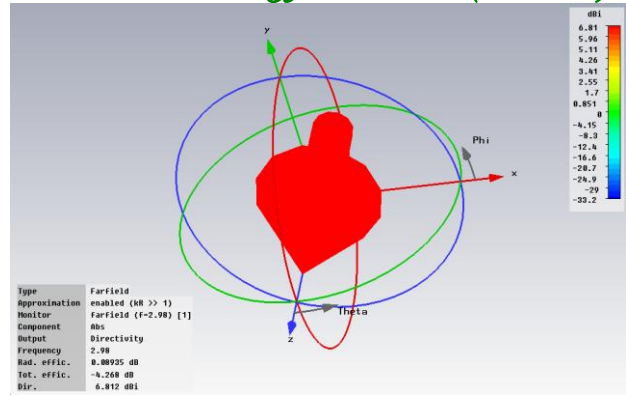

Fig. 4. The far field at frequency F=980MHz

RFID SYSTEM APPLICATIONS

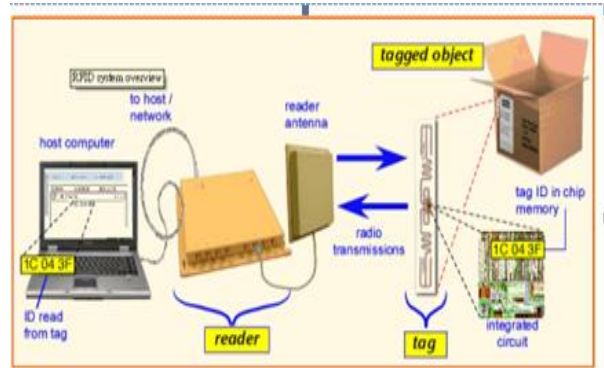

Fig .5.1 RFID systems [2]

RFID OPERATING FREQUENCY BANDS

RFID systems are categorized by; tag powering techniques, and tag-reader communication protocols. These aspects help define read range, cost, and available features. Figure 5.2 lists frequency bands commonly used in RFID systems. LF (125 and 134 kHz) and HF (13.56 MHz) RFID systems utilize inductive coupling with typical read ranges less than 60cm. UHF RFID has read range up to 3m. Microwave (e.g.: 2.4 GHz) RFID systems with radiative coupling have read ranges of approximately 1m due to environmental effects, microwave RFID cannot penetrate water and metal ,along with UHF tags designs that operate near metal and high water content surfaces, UHF RFID systems are gaining popularity [3].

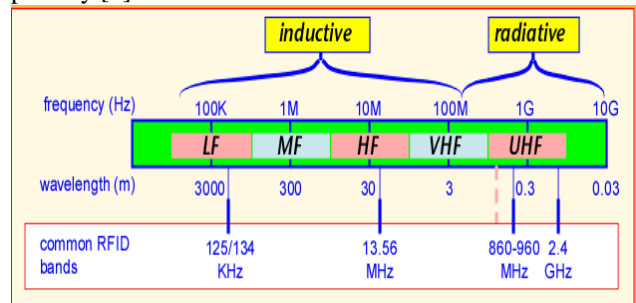

Fig 5.2: RFID frequency Bands [3]

Figure 5 illustrate the Mesh details of the Frequency-Domain Solver in CST MWS while figure.6 and 7 is the S-parameter for designed antenna in linear and dB modes

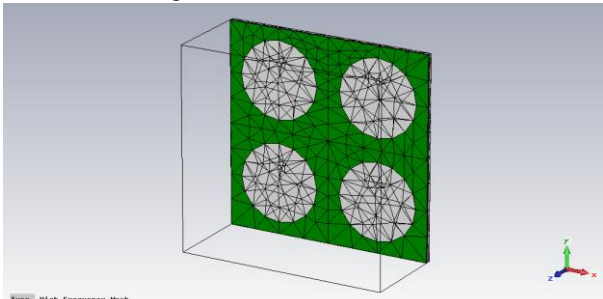

Fig .6 Mesh details of the Frequency-Domain Solver in CST MWS

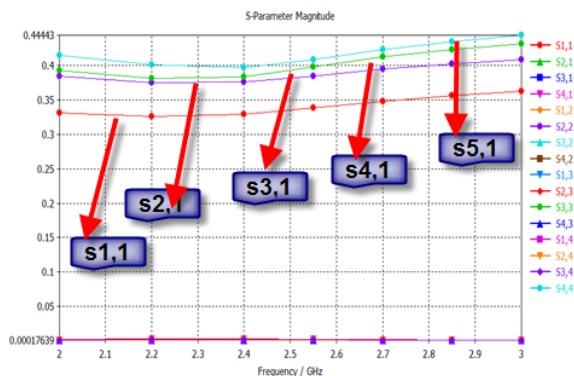

Fig.7 linear S-parameter of design antenna

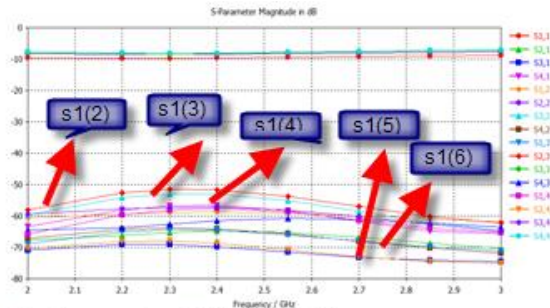

Fig.8 S - parameter of RFID antenna dB

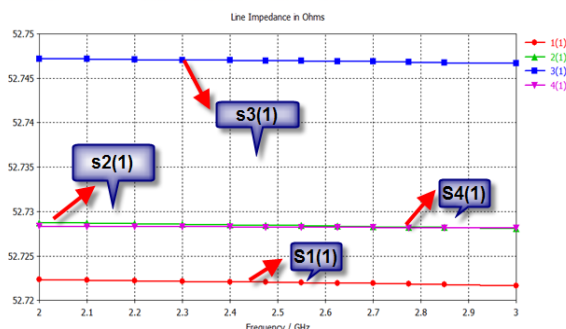

Fig.9 S - impedance of RFID antenna

Figure 8 illustrate the S - parameter of RFID antenna dB while Figure 9 illustrate impedance of RFID antenna and its value near to 50 ohm as shown in figure. Using CST MW

studio has been used to simulate the RFID antenna and all the parameter was shown in figures.

Final Stage

Radio Frequency Identification (RFID) technology is an emerging technology for a broad spectrum of applications including managing goods, tracking the movement of tools, equipment, people, animals or even anti-counterfeiting [3]-[9]. The use of RFID technology improves safety in a variety of applications such as tracking location of miners and in personal protective equipment. RFID retrieves data stored on a tag wirelessly. It comprises of a tag, a reader, and a host computer with data management software [10]-[12]. A full RFID system consists of three major components [13] a) RFID tags (transponders), b) RFID readers (transceivers), and c) application software (Data processing subsystem). Tags are attached to the objects so that every RFID enabled object has its own unique identification (ID) number. Object identification is performed by information exchange between tag and reader via radio transmissions at low/high/ultra-high frequencies (LF/HF/UHF). The tags can be either passive or active based on their power mechanism. Passive tag harvests the energy from the reader antenna radiating near field and responds to reader query by modulating the backscattered signal. They are cheap and long life as compared to active tags that use internal batteries as source of power. However, active tags can operate at longer ranges and typically have a larger capacity, higher data transfer speeds and increased read/write capability [6]. RFID enabled sites will monitor activities and inventory in real time.

Conclusion

Design and simulation of the Radio Frequency Identification (RFID) is present ,main part for RFID is the Antenna, design antenna using CST program to get the real results to calculated the frequency of the antenna design in the new technology of RFID needing long distance for reading of the information, the main core of transmit and receive the information is the antenna so the design of the antenna is relevant in this paper the design and simulation of the antenna is given using CST STUDIO and Micro wind the magnetic field is present , both frequency and time domain signal are simulated S-parameter in both linear and dB are calculating and field energy. We focus on the development of different antennas for both RFID tags and readers including range measurement techniques, and concentrated on application to mining, oil and utility industries and analyze various practical aspects such as its sensitivity to fabrication process and packaging. A main task of our investigation will concentrate on studying the range distance and its effect on the selection, design, shape and geometrical parameters of reader antennas. To improve read orientation sensitivity, we will consider design tags with multiple antennas as well looking into the effect of polarization diversity to minimize such limitation issues. The following tasks will be carried out first

through simulation and once optimized will be fabricated and tested.

ACKNOWLEDGMENT

This work is supported by NSTIP strategic technologies program number 12-ELE2462 in the Kingdom of Saudi Arabia.

Author

Ahmed Telba is with King Saud university Electrical Engineering Department Saudi Arabia (corresponding author e-mail: atelba@ksu.edu.sa). Khalid Jamil was with PSATRI King Saud university (e-mail: kjamil@ksu.edu.sa). This work is supported by NPST program by King Saud University, Project Number 12-ELE2462– 02.

REFERENCES

- [1] D. M. Dobkin, *The RF in RFID: Passive UHF RFID in Practice*. Newnes, 2007.
- [2] "Quick Introduction to RFID," PolyGAIT RFID Tutorial. PolyGAIT, Web. 14 Jan 2010. <http://www.polygait.calpoly.edu/tutorial.htm>.
- [3] M. Abbak, and I. Tekin, "RFID Coverage Extension Using Microstrip-Patch Antenna Array [Wireless Corner]," *Antennas and Propagation Magazine, IEEE*, vol.51, no.1, pp.185-191, Feb. 2009.
- [4] H. Stockman, "Communication by Means of Reflected Power," *Proceedings of the IRE*, vol.36, no.10, pp. 1196- 1204, Oct. 1948.
- [5] W.-K. Chen, *Linear Networks and Systems* (Book style). Belmont, CA: Wadsworth, 1993, pp. 123–135.
- [6] S.-L. Chen, and K.-H. Lin, "A slim RFID tag antenna design for metallic object applications," *IEEE Antennas and Wireless Propagat. Lett.*, vol. 7, pp. 729-732, 2008.
- [7] G. Marrocco, "The art of UHF RFID antenna design: impedance-matching and size-reduction techniques," *IEEE Antennas and Propagat. Magazine*, vol. 50, pp. 66-79, 2008.
- [8] K. Finkenzeller, *RFID Handbook*, 2nd ed. New York: Wiley, 2003.
- [9] P. V. Nikitin, K. V. S. Rao, S. F. Lam, V. Pillai, R. Martinez, and H. Heinrich, "Power reflection coefficient analysis for complex impedances in RFID tag design," *IEEE Trans. Microw. Theory Tech.*, vol. 53, pp. 2721–2715, 2005.
- [10] M. Hirvonen, K. Jaakkola, P. Pursula, and J. Säily, "Dual-band platform tolerant antennas for radio-frequency identification," *IEEE Trans. Antenna Propagat.* vol. 54, pp. 2632-2637, 2006.
- [11] K. V. Seshagiri Rao, P. V. Nikitin, and S. F. Lam, "Antenna design for UHF RFID tags: a review and a practical application," *IEEE Trans. Antenna Propagat.* vol. 53, pp. 3870-3876, 2005.
- [12] G. Marrocco, "Gain-Optimized self-resonant meander line antennas for RFID applications," *IEEE Antennas and Wireless Propagat. Lett.*, vol. 2, pp. 302-305, 2003.
- [13] D. J. Hind, "Radio frequency identification and tracking systems in hazardous areas," *Fifth International Conference on Electrical Safety in Hazardous Environments*, pp. 215-227, 1994