

Minimization of Harmonics Distortion Active Filter Controlled by PI

Sushil Kumar Singh¹, Priyavand Bundela², Department of Electrical and Electronics Engineering, OIST, Bhopal, India;

¹kumarsushilsingh93@gmail.com;

ABSTRACT

Supply of power may also be distorted as a result of irregular operation of the approach of as a result of range of load asymmetrically. When power deliver disturbed an unwanted flicking in voltage and caused of harmonics within the line. These disorders have an effect on the effectively as well as lifetime of the purchaser's devices, for the minimization of the outcome of whole harmonic distortion needs some powerful instruments that are ready to nullify the result of harmonics beneath various load condition. Here proposed managed lively filters for the controlling of complete harmonic distortion. Switching of this active filter may also be managed with the aid of PI controller. Comparative outcome with PI controller and without PI controller are got and outcome shows that PI controller enhance the results.

Keywords: *Total Harmonic Distortion (THD), Controlled Active filter, PI controller, transmission line.*

1. Introduction

Lately, the expanding utilization of force gadgets in the business and industry forms results in sounds infusion and lower force component to the electric force framework [16]. Customarily, with a specific end goal to conquer these issues, aloof R-L-C channels have been utilized. The utilization of this sort of channels has a few drawbacks. As of late, because of the advancement in present day power gadgets, new gadget called "shunt dynamic force channel (SAPF)" was examined and perceived as a feasible different option for the detached channels. The guideline operation of the SAPF is the era of the proper current sounds required by the non-direct load. Truth told dynamic channels don't show all the normal downsides of latent frameworks, for example, the detuning of single tuned channels because of changes of framework agent conditions and encompassing environment or the era of reverberation at specific frequencies, between the system and channel reactance, that increases undesirable sounds. Dynamic force channels are more catching the enthusiasm of scientists and businesses inferable from the diminishing nature of force supplied by the electrical appropriation organizations and the troubles in satisfying the limitations forced by national and universal guidelines just by utilizing conventional remunerating techniques. The utilization of dynamic frameworks for remunerating

consonant bending and receptive force in the supply electrical systems, both at client level or at a higher voltage level, is presently all the more regularly liked to the traditional uninvolved repaying strategies. In a present day electrical dissemination framework, there has been a sudden increment of nonlinear burdens, for example, power supplies, rectifier hardware, residential apparatuses; flexible rate drives (ASD), and so on. As the quantity of these heaps expanded, sounds streams produced by these heaps might turn out to be extremely noteworthy. This harmony can prompt an assortment of distinctive force framework issues including the twisted voltage waveforms, hardware overheating, breakdown in framework assurance, extreme nonpartisan streams, light flash, mistaken force stream metering, and so forth. To diminish symphonious contortion and power element change, capacitors are utilized as inactive channels. Be that as it may, they have the disadvantage of massive size, segment maturing, reverberation and settled pay execution. These give either over-or under-remuneration of music, at whatever points a heap change happens [4]. So as to conquer these issues, dynamic force channels (APFs) have been produced. The voltage-source-inverter (VSI) - based shunt dynamic force channel has been utilized as a part of late years and perceived as a practical arrangement [5]. Dynamic channels, also, allow the control and the remuneration of bended line streams adjusting to the heap changes and to changing in working recurrence. The best and the most diffuse structure in dynamic separating frameworks is surely the shunt one made by an inverter sustained by a capacitor and an aloof channel used to infuse the repaying streams in the network (Fig. 1). Keeping in mind the end goal to conquer these issues, dynamic force channels (APFs) have been created. The voltage-source-inverter (VSI) - based shunt dynamic force channel has been utilized as a part of late years and perceived as a practical arrangement [5]. The control plan, in which the required sensing so as to repay streams are dictated line ebbs and flows just, is given in [6]-[7], which is basic and simple to actualize. The plan utilizes an ordinary corresponding in addition to necessary (PI) controller for the era of a reference current layout. As of late, fluffy rationale controller has created a lot of enthusiasm for different applications and has been presented in the force hardware field [8]-[10]. The upsides of fluffy rationale controllers over

the routine PI controller are that they needn't bother with a precise numerical model; they can work with uncertain inputs, can deal with nonlinearity, and may be more vigorous than the customary PI controller. Utilization of fluffy rationale for minimization of sounds and change of force quality is not another issue rather different creators have presented some inventive techniques utilizing these devices [11]. The most essential perception from the work reported by different analysts for force quality change is the configuration of dynamic force channel under 'settled burden' conditions or for burdens with moderate and little variety [12]. In this section a fluffy rationale controlled SAPF for current music end is displayed. The control plan depends on two FLCs, the first controls the dc transport voltage and the second one controls the yield current of the inverter.

2. The Active Power Filter

At the point when straight loads are associated with the supply the waveforms are direct. While non straight loads are associated symphonious shows up on electric voltage or current. The music is whole number products of framework recurrence. This prompts different force quality issues like warming of the gadgets, mis-triggering of the drives, throbbing yield in the engines, and so that, a consonant channel are utilized to wipe out the music. There are three fundamental sorts of sounds channels given beneath. APF is a kind of channel that uses either current or voltage source as its real segment. They remunerate voltage or current music by infusing the negative of the consonant sign measured infused signals nourished are of same greatness yet in stage resistance with the deliberate symphonious signs. It is controlled to draw/supply a remunerated current from/to the utility, such that it disposes of responsive and consonant streams of the non-straight load. Along these lines, the subsequent aggregate current drawn from the air conditioner mains is sinusoidal. In a perfect world, the APF needs to produce simply enough responsive and consonant current to remunerate the non-straight loads in the transmission line [2]

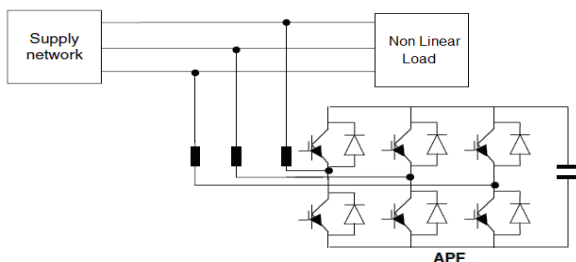

Figure 1 Active power filter connected with transmission line

3. Controllers used for controlling of Active Filter

Fig. 2 demonstrates the dynamic force channel remuneration framework with PI control plan. To actualize the control calculation of a shunt dynamic force channel, the DC capacitor voltage (V_{dc}) is detected and contrasted and the reference esteem (V_{dcref}). The Input of PI controller is the estimation of Error, $e = V_{dcref} - V_{dc}$, and its yield, after a point of confinement, is considered as the greatness of top reference current I_{max} . The exchanging signal for the PWM converter are gotten from looking at the genuine source streams (i_{sa}, i_{sb}, i_{sc}) with the reference current formats (I_{sa}, I_{sb}, I_{sc}) in a hysteresis current controller. The yield heartbeats are connected to the exchanging gadgets of the PWM converter [14]. Since coefficients of PI controller, K_p and K_i , are altered in this model, the execution of dynamic force channel under arbitrary burden variety conditions is not and in addition 'settled burden' condition. To conquer this issue and make a hearty controller, a fluffy rationale controller is intended to tune K_p and K_i on the base of burden current wort

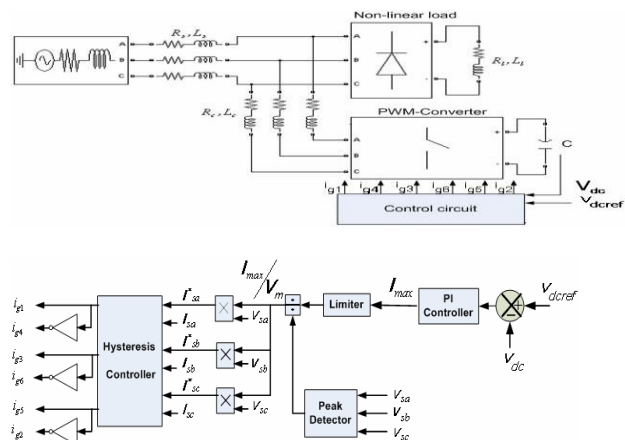

Figure 2 a) Active filter system b) Active filter system using PI controller

4. Simulink model of Active power filter using Fuzzy controller.

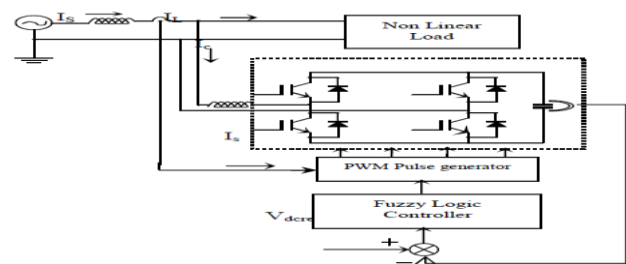

Figure 4 Block Diagram of Fuzzy controlled improved power quality converter

Figure 4 shows the block diagram of PI/Fuzzy controller used for the controlling of active power filter. The simulation is done using MATLAB for the fuzzy logic controlled voltage source PWM rectifier. The complete rectifier system is composed of mainly (1) three phase source, (2) voltage source PWM rectifier, (3) fuzzy controller, and (4) hysteresis controller.

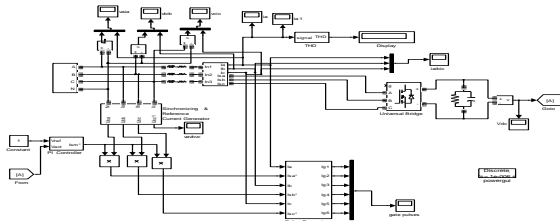

Figure 5 Simulated power circuits without controlled improved power quality converter

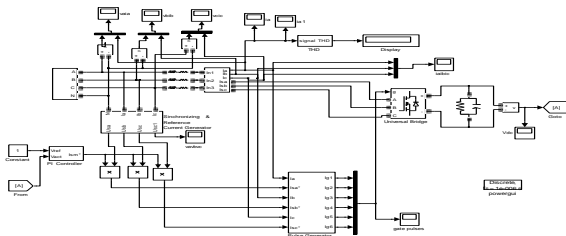

Figure 6 Simulated power circuit for PI controlled improved power quality converter

5. Simulation Results

The current and voltage waveform of the ordinary three stage rectifier without controller is appeared in fig 7.

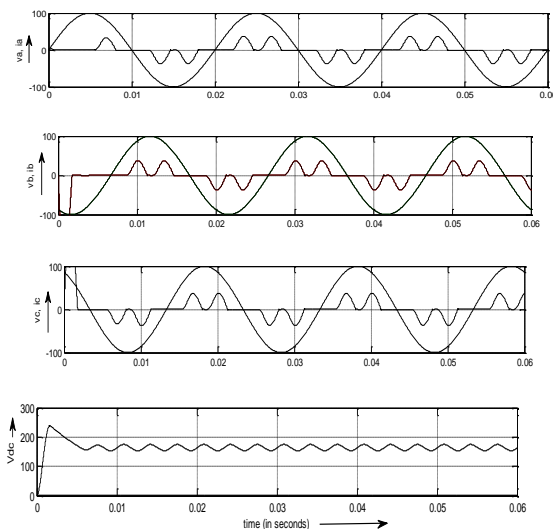

Figure 8 Waveform without controller

The present waveform for one cycle and its harmonica range is appeared in fig 8 (a) and (b). The current is non sinusoidal

and complete harmonica bending (THD) is high (88.84%). To make the current sinusoidal and THD inside reasonable farthest point current controller is utilized.

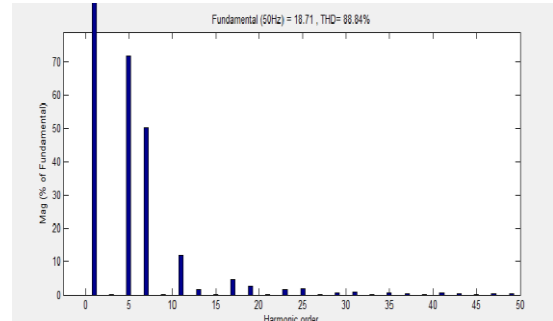

Figure 9 Harmonics spectrum without controller

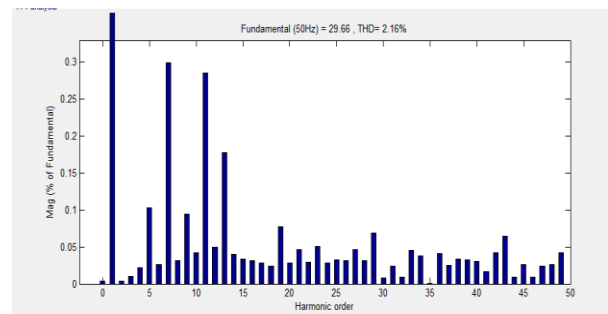

Figure 10 Harmonics spectrum with PI controller

Table 1: Comparative Analysis of THD by Using Various Controllers

S. No.	NAME OF CONTROLLER	THD
1	No Controller Used	88.84%
2	PID Controller	2.16%

6. Conclusion

Taking into account the reproduction results, it can be presumed that, fluffy rationale controlled PWM rectifier performs attractive for the remuneration of line current. After remuneration, line current get to be sinusoidal, adjusted and in stage with the separate source voltage and decreases the THD of the source current beneath 5% limit. It is clear from reenactment come about that the transient execution of the source current and DC side capacitor voltage is better for the fluffy controller contrasted with the PI controller in term of the setting time and % rise/fall in DC join voltage. The consistent state execution of the fluffy controller is tantamount with that of PI controller.

References

- [1]. G.K. Singh, A.K. Singh, R. Mitra., “a simple fuzzy logic based robust active power filter for harmonics minimization under random load variation” *Electr. Power Syst. Res.* (2006). B. S., Malesani L., Mattavelli P., 1998, *IEEE Trans. on Ind. Electron.*, Vol. 45,722-729.
- [2]. W. M. Grady, M. J. Samotyj, and A. H. Noyola, “Survey of active power line conditioning methodologies,” *IEEE Trans. Power Del.*, vol. 5,no. 3, pp. 1536-1542, Jul. 1990.
- [3]. V. E. Wagner, J.c. Balda, D. C. Griffith, A. McEachern, T.M.Barnes, D.P. Hartmann, D.J. Philleggi, A.E. Emmanuel, W.F. Hortion, W.E. Reid, R.J. Ferraro, W.T. Jewell, Effects of harmonics on equipments, *IEEE Trans. Power Deliv.* 8 (2) (1993) 672-680.
- [4]. B. Singh, A. Chandra, and K. Al-Haddad, “Computer-aided modeling and simulation of active power filters,” *Elect. Mach. Power Syst.*, vol. 27, pp. 1227-1241, 1999.
- [5]. K. Chatterjee, B. G. Fernandes, and G. K. dubey, “An instantaneous reactive volt-ampere compensator and harmonic suppressor system,” *IEEE Trans. Power Electron.* vol. 14, no. 2,pp. 381-392, Mar. 1999.
- [6]. S. Jain, P. Agarwal, and H. O. Gupta, “Design simulation and experimental investigations on a shunt active power filter for harmonics and reactive power compensation,” *Elect. Power Compon. Syst.*, vol.32, no. 7, pp. 671-692, Jul. 2003.
- [7]. B. K. Bose, *Expert Systems, Fuzzy Logic and Neural Network Application in Power Electronics and Motion Control.* Piscataway, NJ: IEEE Press, 1999.
- [8]. V. S. C. Raviraj and P. C. Sen, “Comparative study of proportional integral, sliding mode, and fuzzy logic controllers for power converters, ”*IEEE Trans. Ind. Appl.*, vol. 33, no. 2, pp. 518-524, Mar./Apr. 1997.
- [9]. Dell’Aquila, A. Lecci, and V. G. Monopoli, “Fuzzy controlled active filter driven by an innovative current reference for cost reduction,” in *proc. IEEE Int. symp. Ind. Electron.*, vol. 3, May 26-29, 2002, pp. 948-952.
- [10]. J. A. Momoh, X.W. Ma, K. Tomsovic, Overview and Literature survey of fuzzy set theory in power systems, *IEEE Trans. Power Syst.* 10 (August (3)) (1995) 1676-1690.
- [11]. G.K. Singh, A.K. Singh, R. Mitra., “a simple fuzzy logic based robust active power filter for harmonics minimization under random load variation” *Electr. Power Syst. Res.* (2006).
- [12]. Recommended Practices and Requirements for Harmonic Control in Electronic Power Systems, *IEEE Standard 519-1992*, New York, 1993.
- [13]. C. N. Bhende, S. Mishra, and S. K. Jain, “TS-Fuzzy-Controlled Active Power Filter for Load Compensation”, *IEEE Transactions on Power Delivery*, Vol. 21, No. 3, July. 2006.
- [14]. A. Elmitwally, S. Abdelkader, M. Elkateb “Performance evaluation of fuzzy controlled three and four wire shunt active power conditioners” *IEEE Power Engineering Society Winter Meeting*, 2000. Volume 3, Issue, 23-27 Jan 2000 Page(s):1650 – 1655 vol.3.
- [15]. Emanuel A E. (2004). Summary of IEEE Standard 1459: Definitions for the Measurement of Electric Power Quantities under Sinusoidal, Non-sinusoidal, Balanced or Unbalanced Conditions. *IEEE Trans. Ind. Appl.*, Vol.40, No.3, pp.869-876.